

# Sunflower Test and Testpulser

## 1.) Sunflower test setup

## 2.) First results

- noise performance (M. K.)
- crosstalk (M.K)
- hitrate regulation (S. Menchikov)
- linearity (G. Matthiae)
- fluctuation analysis (H. Gemmeke)

## 3.) Discussion of testpulser scheme

- test pulser at HE
- pattern generator at analog board

## 4.) Conclusion

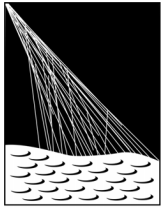

## Setup for Sunflower Test

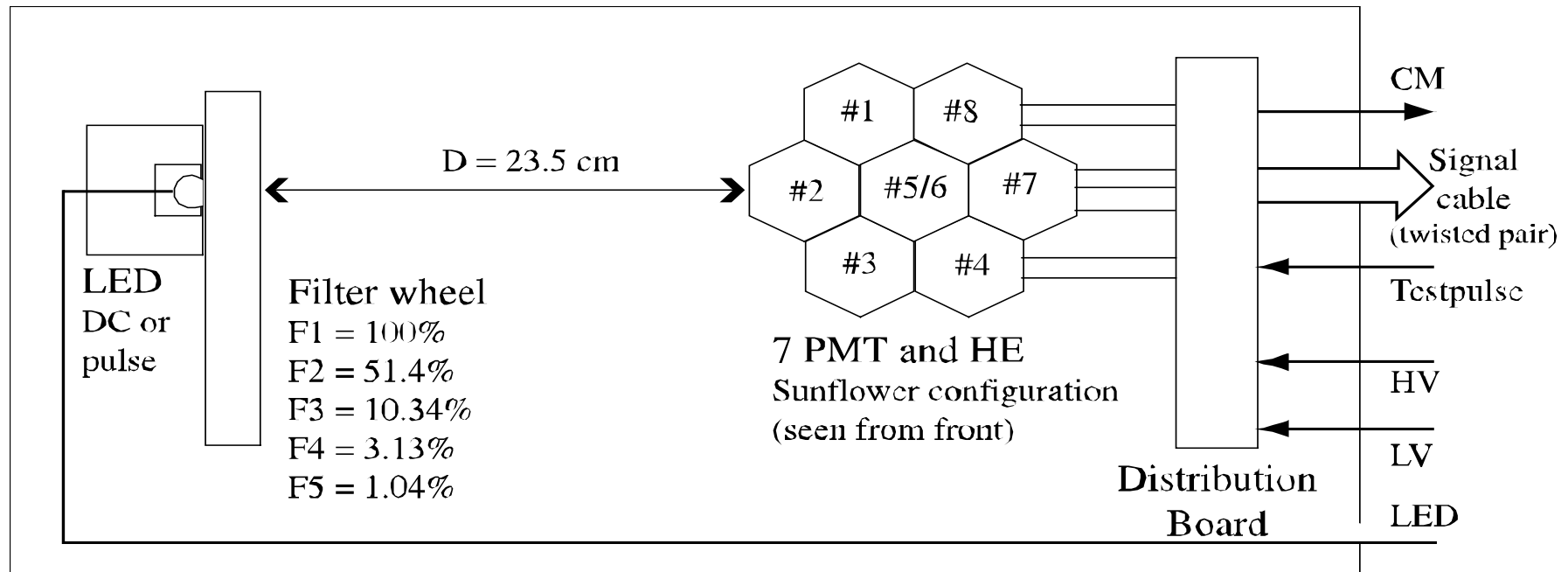

- **8 (+2) channels readout**, triggered by external trigger (pulse generator)
- gain set to mean value (128) for all channels, but PMT **gain  $0.7..1.7 \cdot 10^5$**
- **constant DC light background** possible by second LED

## What was done?

### 1. Sunflower Test (22.-26. May), bug in readout software

- connection test, responds of full readout chain to LED pulses
- gain adjustment, improved grounding
- measurement of noise and crosstalk
- measurement of linearity
- linearity with sky noise (=DC light source)

### 2. Sunflower Test (17.-21. July), improved statistic

- check noise and grounding
- test hitrate regulation at different light levels
- measure linearity (of sum channel with high signals)

Note: most data were recorded with **virtual channel** (VC) option, a few measurements with **(bilinear) compressor** (CO)

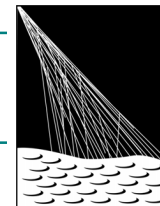

## Typical Pulse

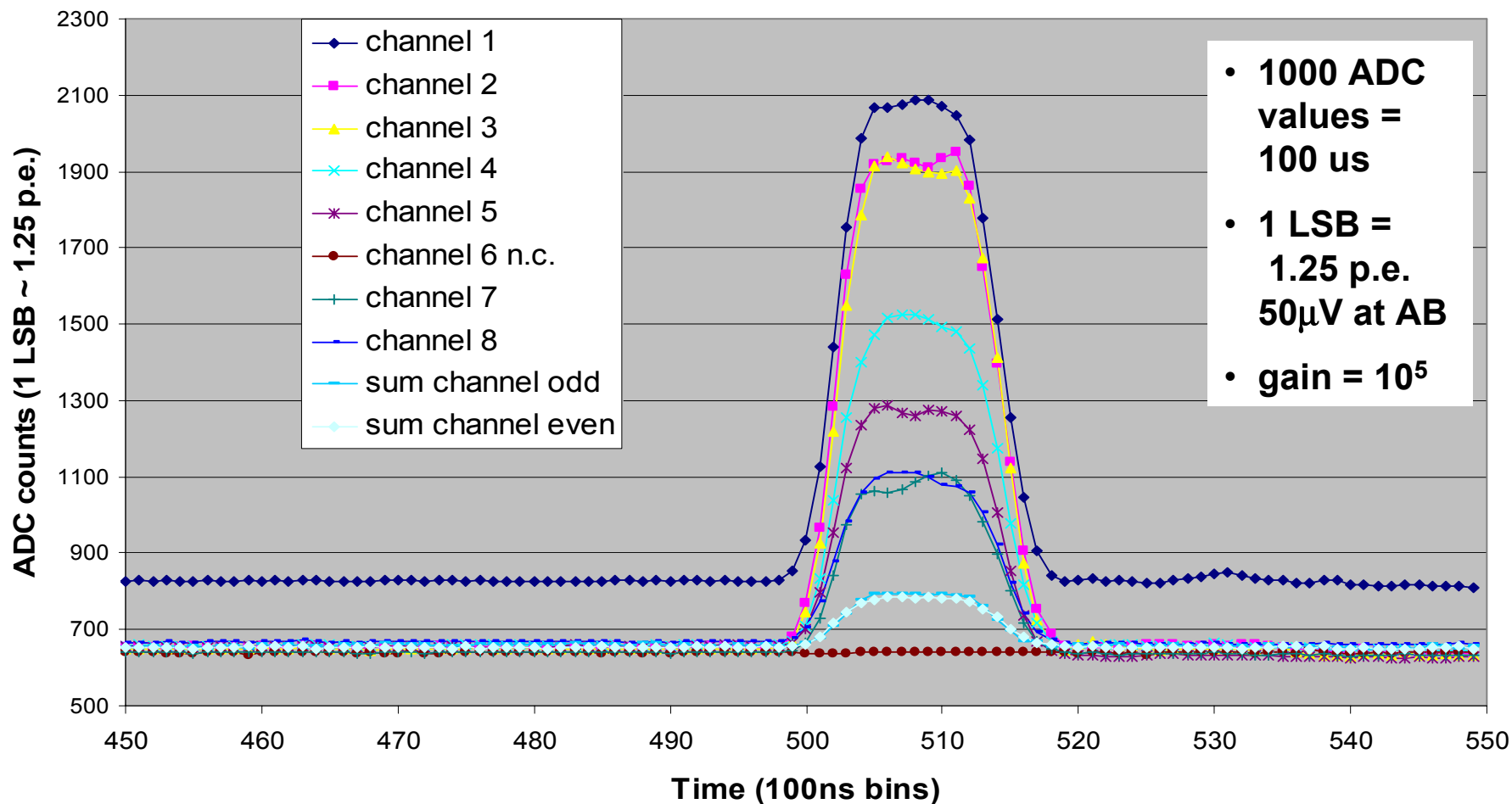

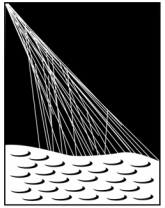

## Noise optimum and grounding:

Channel	#1	#2	#3	#4	#5	#6	#7	#8	#odd	#even
Gain ( $10^5$ ):	1.7	1.6	1.4	1.1	0.9	n.c.	0.7	0.9	--	--
Noise (LSB):	1.06	0.98	2.01	0.94	1.26	0.67	1.03	0.78	2.20	1.57
Offset (chan):	824.5	653.6	648.0	656.6	654.8	638.9	639.6	666.5	656.1	653.1

- main reduction by connecting LV-GND with GND of FEB subrack
- no effect by grounding the shielding of the twisted pair (on one end)
- no effect by shielding the HE and PMT with aluminum foil (connected to GND)
- noise reduction by unshielded but only 1.5m cable in some channels

### Comments:

- channel 1 with modified gain and ADC input range 0..2 V (instead 0..4 V) to avoid saturation
- channel 5 connected to 6 due to bad contact
- channel 3 is known to be noisy (like seen in first test )
- saturation effects of transformer (especially for long pulses) and undershoots

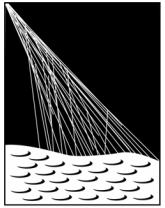

### Crosstalk, signal in chn. 4

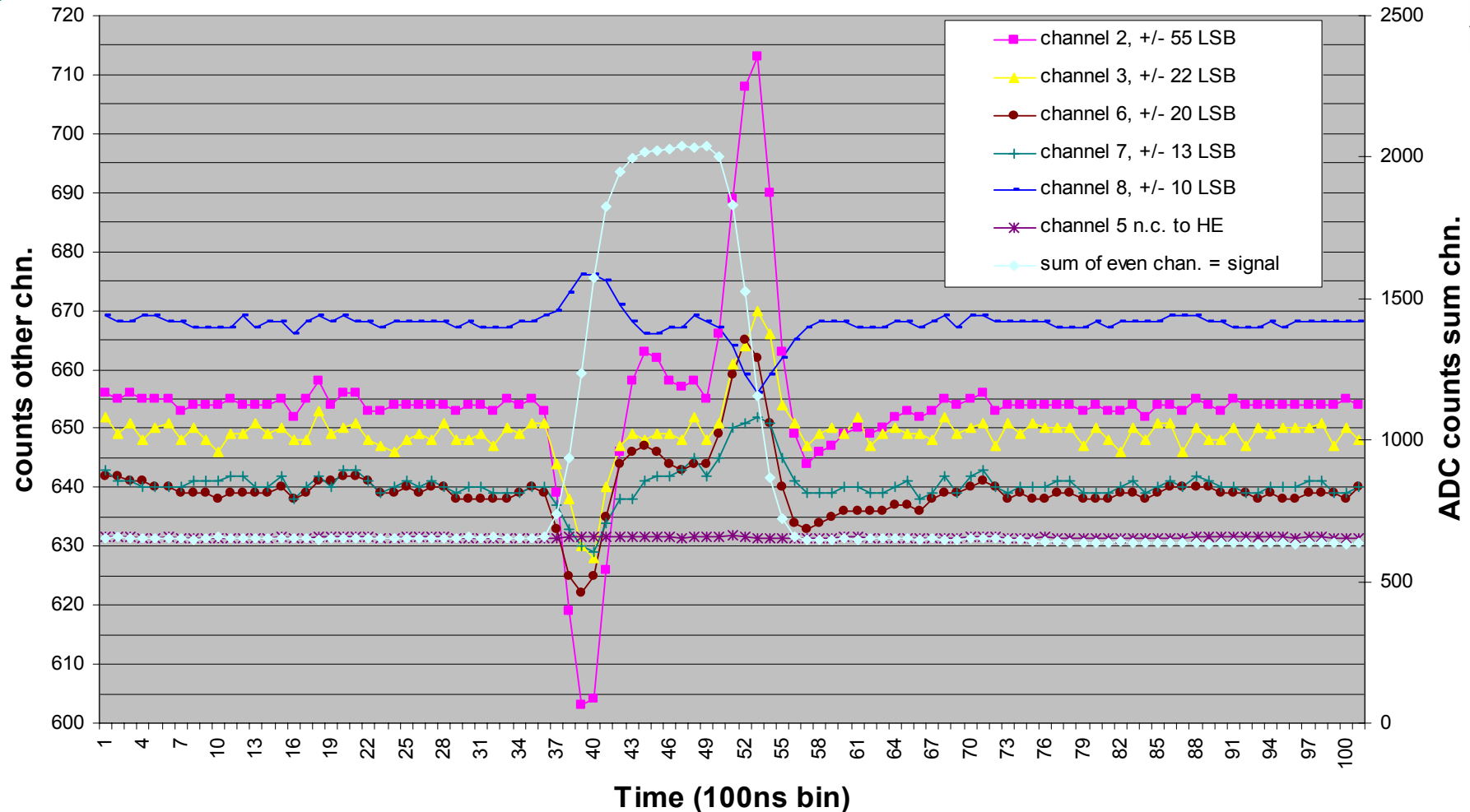

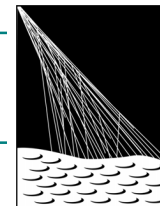

# Different Testpulsers Systems

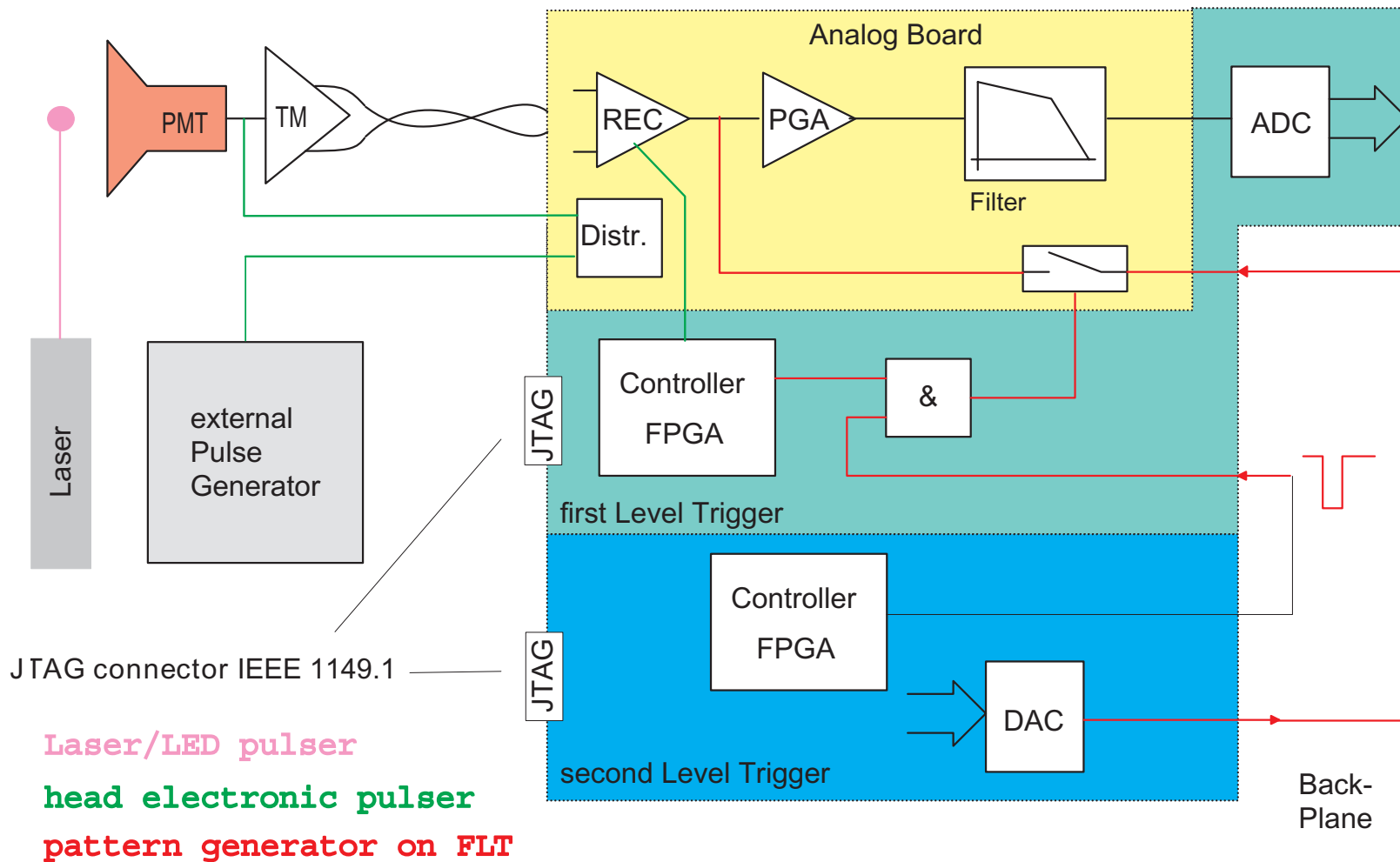

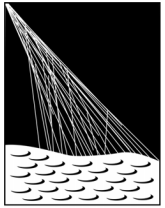

## Pro & Contra Test Pulsar Schemes

### Pulsar at Head Electronic (HE)

- + test full chain with arbitrary pulse shape
- + relative calibration of channels
- = pulse across boards, not overlapping pulses inside board
- worse noise behavior (10 LSB)
- additional effort at HE and DB
- additional -12 V power at FE
- additional ext.. pulse generator

### Pattern Generator at front-end (FE)

- + test of chain from front-end input
- + arbitrary width and amplitude
- + relative calibration of channels
- + arbitrary timing inside and across boards (real pattern generator)
- + no noise increase (already tested)
- additional switches at analog board

**Is Pulsar at HE really necessary?**

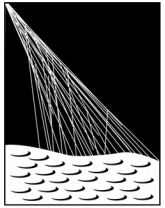

## Summary of Sunflower Test

- Full signal chain tested successful, **noise  $\approx 1$  LSB, x-talk  $< 0.3$  %**
- linearity adequate (low gain range)
- check of full dynamic range limited due to transformer saturation
- hit rate measurement and regulation successful
- measurement of anode current via variance of ADC data possible
- CM at HE is working, but readout with  $\Sigma$ - $\Delta$ -ADC failed
- performance of compressor worse compared to virtual channel
  - noise  $\approx 1.5 \dots 3$  **LSB** (compared to 1 LSB)
  - power consumption 700..800mA @ $\pm 8$ V (compared to 500mA)
  - very difficult to handle and to calibrate
  - with current diodes non-linear